

# Machine Eracer 180

14+  
AGES



**INSTRUCTION MANUAL**

**Machine  
Racer 180**



## ENJOY THE FPV RACING

*Experience the passion of flight Faster,  
more stable picture, smaller, more powerful*



# Table of Contents

1.0 Know your drone	2
2.0 Specification	3
2.1 Specification of the camera -----	4
2.2 Imaging parameters -----	5
3.0 Notice in Flight	6
4.0 Charging -----	6
5.0 Assembling of the drone -----	7
5.1 Install of the blade propellers -----	7
5.2 Installing battery -----	7
6.0 Ready to fly -----	8
6.1 Charging of the drone -----	8
6.2 Motor unlocking/locking -----	8
7.0 End of flying	9

## 1.0 Know your drone

- The main structure is made of Carbon Fiber Composite materials,with the advantages of super toughness and resistance of impact force and so on.
- New industrial and modular design,improved the product variety,easy to install,maintain,replace and update.
- Equiped with 5.8G real-time image transmission system,bring you different visual effects.

1. F3 6DOF flight control
2. KF 180 steering engine
3. 20A ESC
4. Forward Motor
5. Motor reverse
6. Positive blade (black cap)
7. Anti-blade (blue cap)

8. Camera
9. image transmission
10. 4S 30C 1100mAh battery
11. PVC Case
12. Mushroom antenna
13. Receiver(optional)

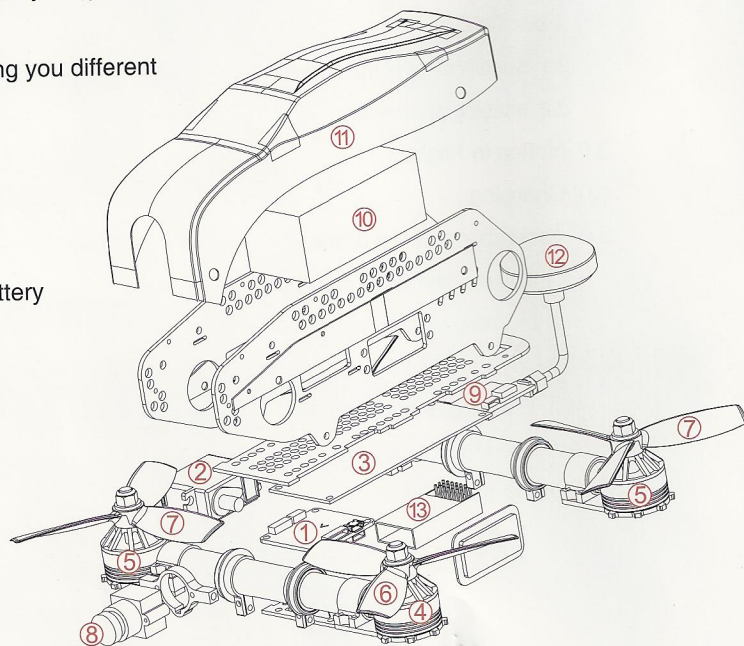

## 2.0 Specification

### Specification of the drone

main wing : 55mm

airframe ( length×width×height ) : 200×180×94mm

weight : 397g ( not including battery )

Controller : 2.4G 6 channels

Receiver : integration 6 channels

Flight Control : F3 flight control appliance

Motor : 2205-2300KV

ESC : 20A

Li-Battery : 14.8V 1100mAh 30C 4S Li-Po

Fly time : 10~14 mins

Working temperature : -10°C to +40°C

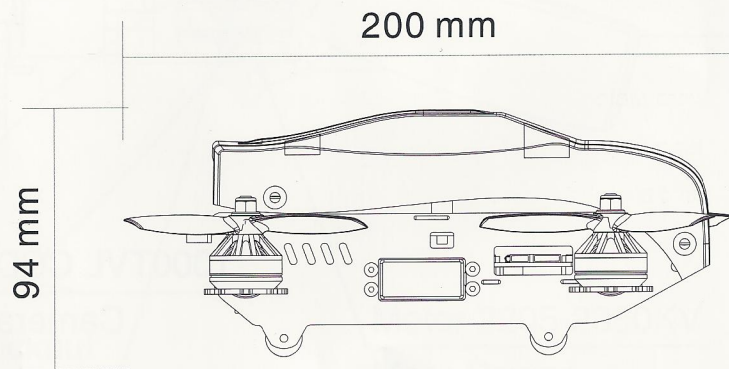
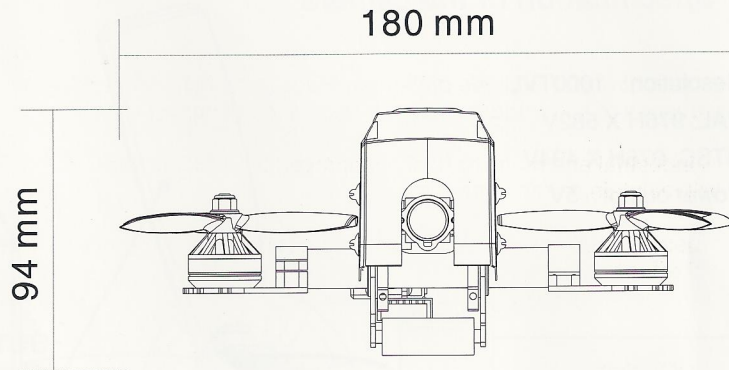

## 2.1 Specification of the camera

- Resolution: 1000TVL
- PAL: 976H X 582V
- NTSC: 976H X 494V
- Power output: 5V

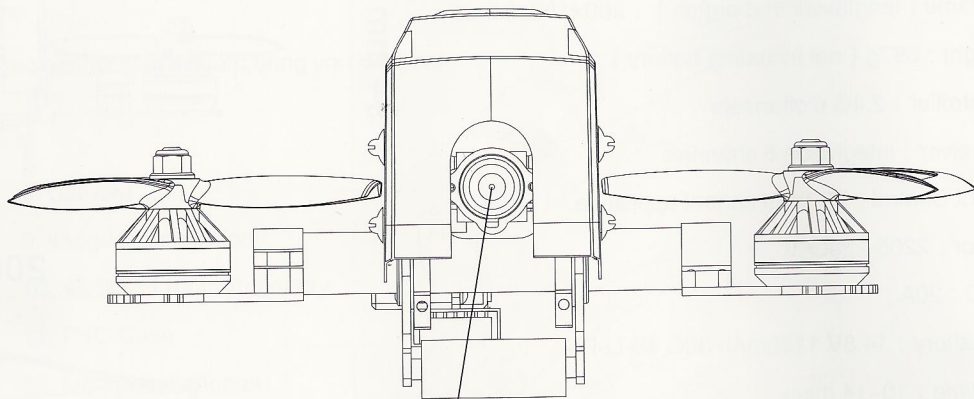

1000TVL CCD	Support N / P switch
Camera	Support Night Flight

## 2.2 Imaging parameters

- 4-inch three-blade propeller
- Motor 2205-2350KV
- Double locknut

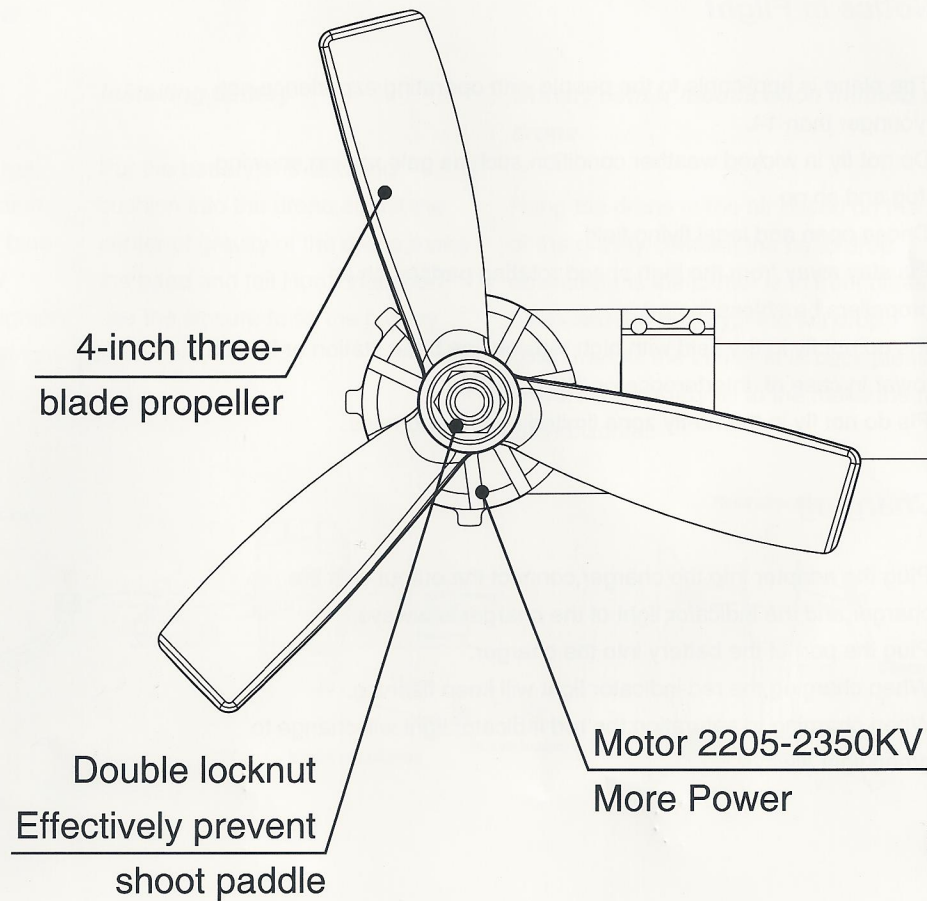

### 3.0 Notice in Flight

- ( 1 ) The plane is applicable to the people with operating experience,not younger than 14.
- ( 2 ) Do not fly in wicked weather condition,such as gale,raining,snowing, fog and so on.
- ( 3 ) Chose open and legal flying field.
- ( 4 ) Pls stay away from the high speed rotating parts(such as propellers,brushless motor)
- ( 5 ) Pls do not fly in the field with high tension line,base station or launch tower,in case of interference on RC controller.
- ( 6 ) Pls do not fly in the no-fly zone limited by law and rules.



Power plug

### 4.0 Charging

- (1) Plug the adapter into the charger,connect the output with the charger,and the indicator light of the charger is always.
- (2) Plug the port of the battery into the charger.
- (3) When charging,the red indicator light will keep flashing.  
When charging to saturation,the red indicator light will change to green light always.

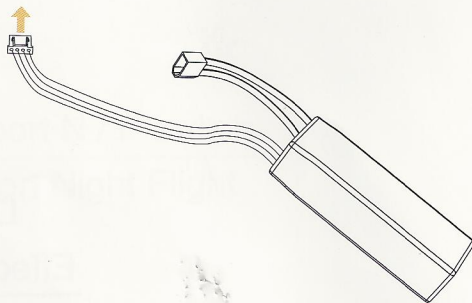



## 5.0 Assembling of the drone

### Install of the blade propellers

Install the forward propeller(with black nut) on the forward motor as the arrow direction show,install the reversed propeller(with blue nut) on the reversed motor as the arrow direction show,screw the propellers to tighten by hand,make sure the propellers installing correctly and solidly.

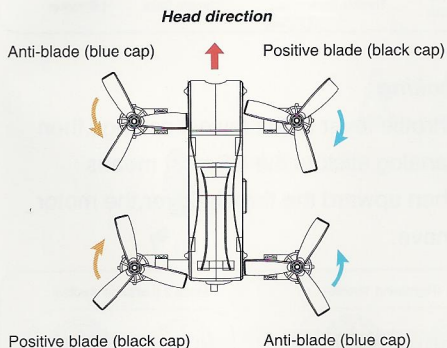

### Installing battery

Put the battery,anti-skidding cushion into the drone,adjust the center of gravity of the drone,make the head and tail Horizontal,then use the closure to fix the battery.

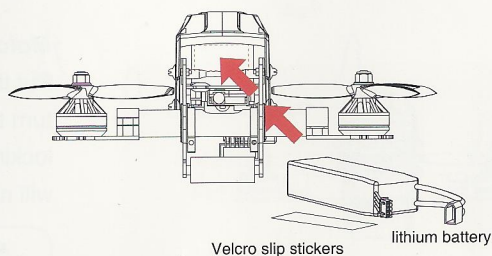

### Gravity center modification method of the drone

Hang the drone in the air based on the fulcrum of the gravity center,if the head drop down,means the center is in front,please backward the battery;if the tail drop down,means the center is in back,please forward the battery,till to the make the head and tail horizontal.

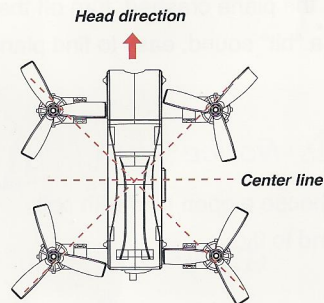

## 6.0 Ready to fly

### 6.1 Charging of the drone

Make the drone stayed horizontal, connect the power of the drone.

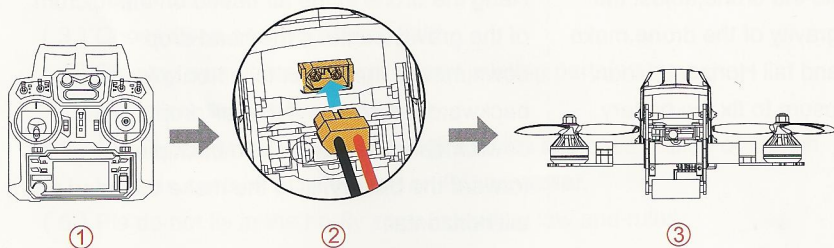

When the plane crashed, turn off the remote control aircraft, the aircraft will issue a "bit" sound, easy to find plane

### ⚠ Notice

Choose a open field with soft land to fly.

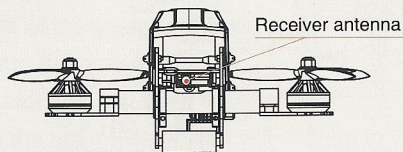

### ⚠ Notice

Erect the receiving antennas before flying, to increase the distance of communication.

## 6.2 Motor unlocking/locking

### Motor unlocking

Upward all the switches of the RC controller, put the throttle lever to the lowest setting, open the power of the controller, make the SWC to the middle, turn the analog stick to the rightmost, if the plane make dripping sounds means motor unlocking, then upward the throttle lever, the motor will move

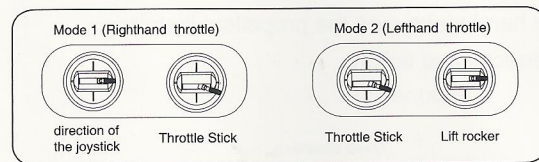

### Motor locking

Put the throttle lever to the lowest settings, then turn the analog stick to the leftmost means locking, then upward the throttle lever, the motor will not move.

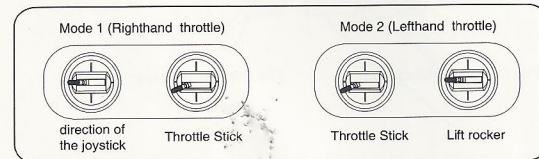

## Notice

- ① Crossing fly is more applicable for the operator with experience
- ② When crossing flying, please flying in the sight of 50m or in the range of 300m with video receiving (the actual range is depended on the weather condition and flying environment)
- ③ When crossing, please avoid the obstacle such as crowd, animals and high tension line and so on.

### Crossing fly

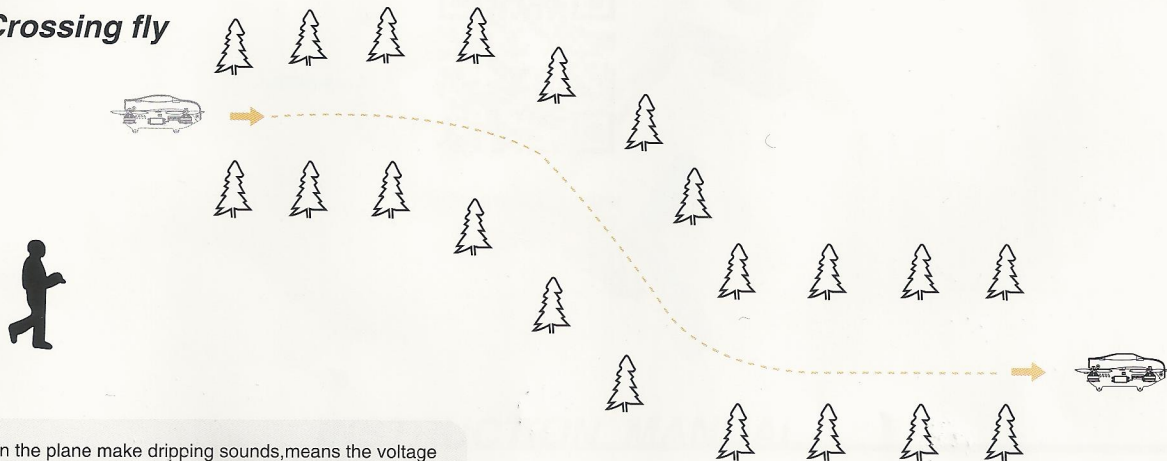

When the plane make dripping sounds, means the voltage of the battery is low, please land the the plane as soon as possible, in case of crashing and so on.

## 7.0 End of flying

- ① Landing by hand
- ② Close the power of the plane, then close the power of the rc controller
- ③ Take out the battery from the plane.

**Eachine**  
**Eracer 180**



[www.eachine.com](http://www.eachine.com)

FCCE